

4

3

2

1

THIS DRAWING IS UNPUBLISHED. RELEASED FOR PUBLICATION
 © COPYRIGHT BY TYCO ELECTRONICS CORPORATION. ALL RIGHTS RESERVED.

LOC	DIST	REVISIONS			
P	LTR	DESCRIPTION	DATE	DWN	APVD
DW	—	ECR-07-010411, CHANGE TERMINAL'S PROFILE	04MAY07	OH	WK

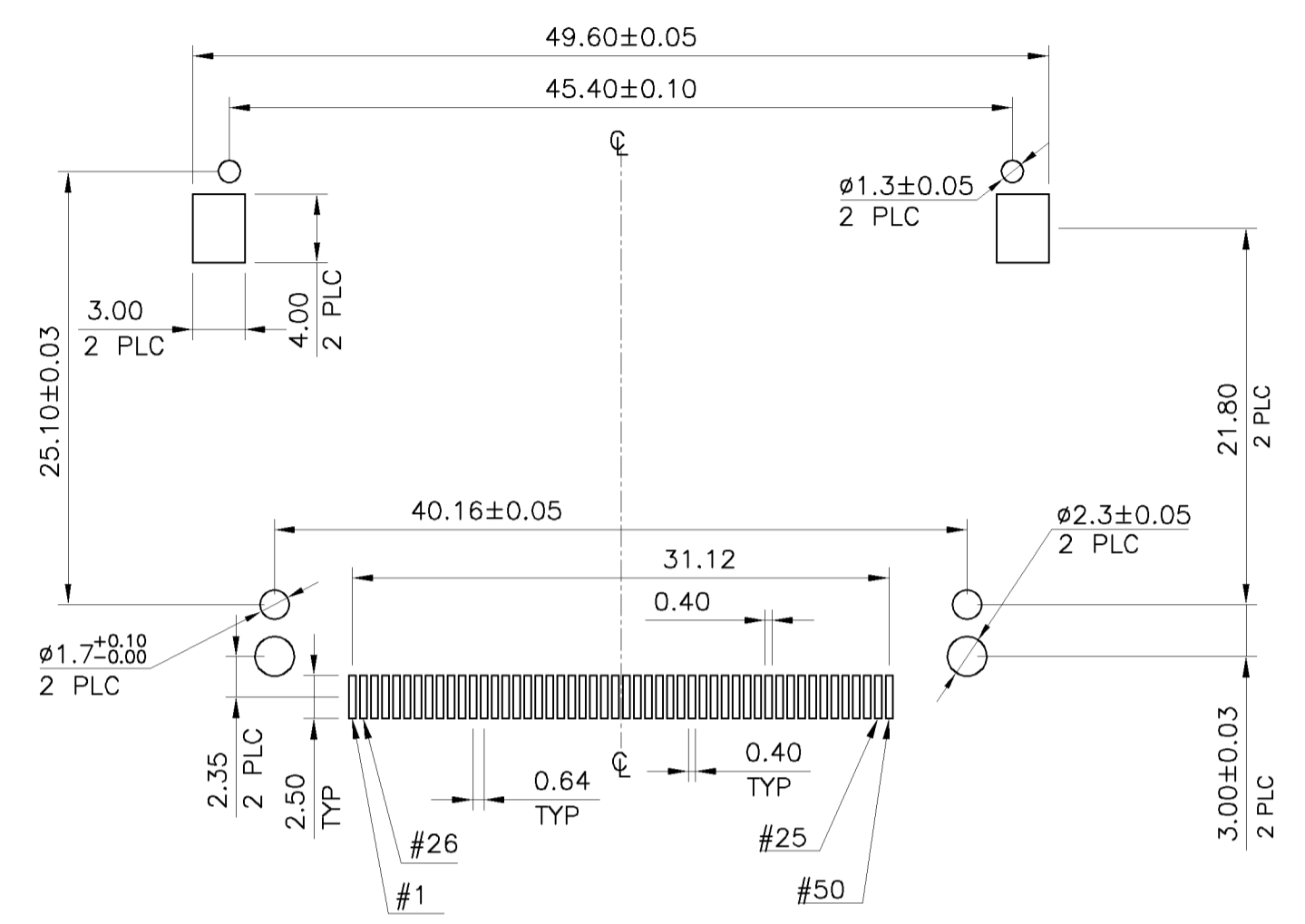
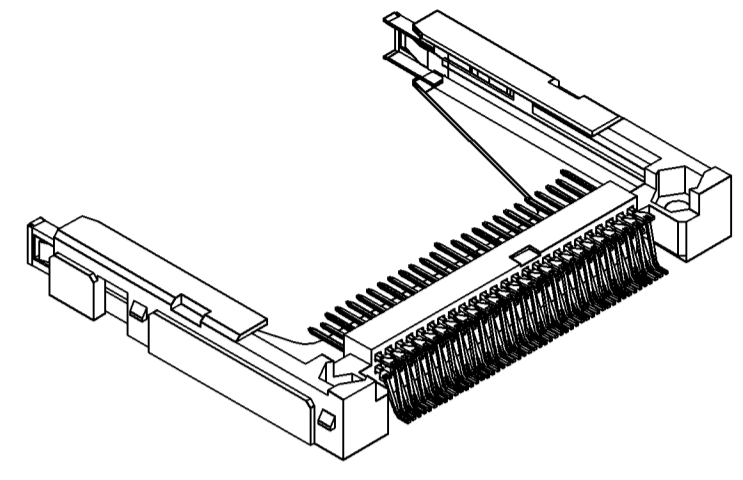
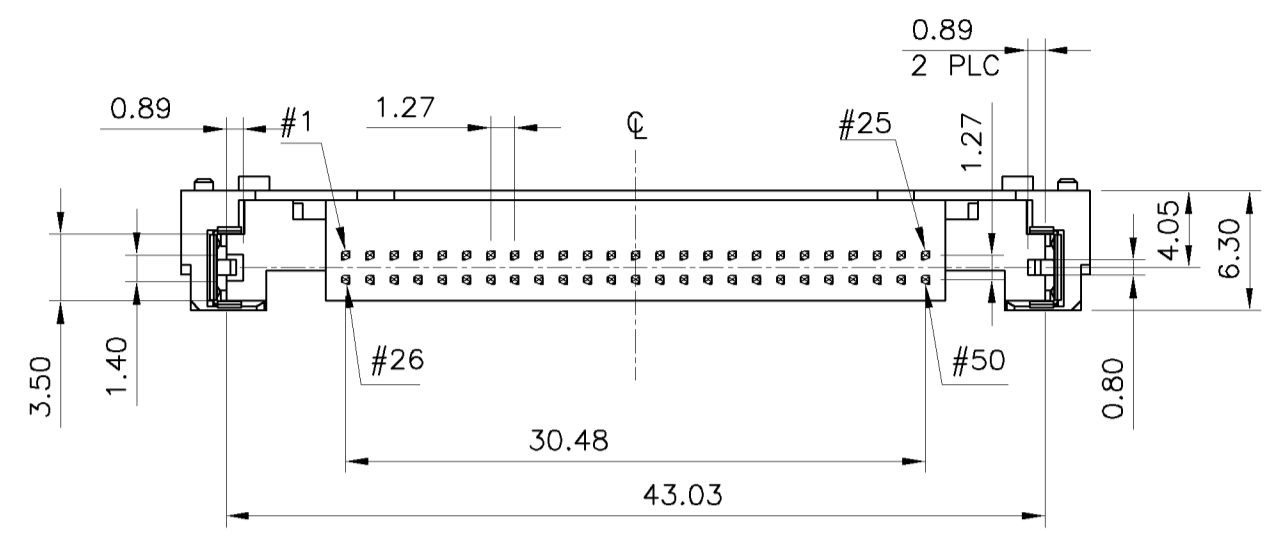

RECOMMENDED P.C.B LAYOUT

NOTE:

- MATERIAL:
 HOUSING: LCP WITH 30% GF, UL 94V-0, WHITE COLOR.
 CONTACTS: BRASS.
 MOUNT EAR: BRASS.
 GROUNDING: PHOSPHOR BRONZE.
- FINISH:
 CONTACTS: 0.381µm [15µ"] GOLD PLATED ON CONTACT AREA,
 2.54µm [100µ"] MIN. MATTE-TIN ON SOLDER TAIL, WITH
 ENTIRE CONTACT UNDERPLATED 1.27µm [50µ"] MIN. NICKEL.
 MOUNT EAR: 2.54µm [100µ"] MIN. TIN PLATED ON SOLDER AREA
 1.27µm [50µ"] MIN. NIKEL UNDERPLATED ALL OVER.
 GROUNDING: 2.03µm [80µ"] MIN. NIKEL UNDERPLATED ALL OVER.
- REFLOW SOLDER CAPABLE TO 260°C PER TYCO TEST SPEC.
 109-201, CONDITION B.

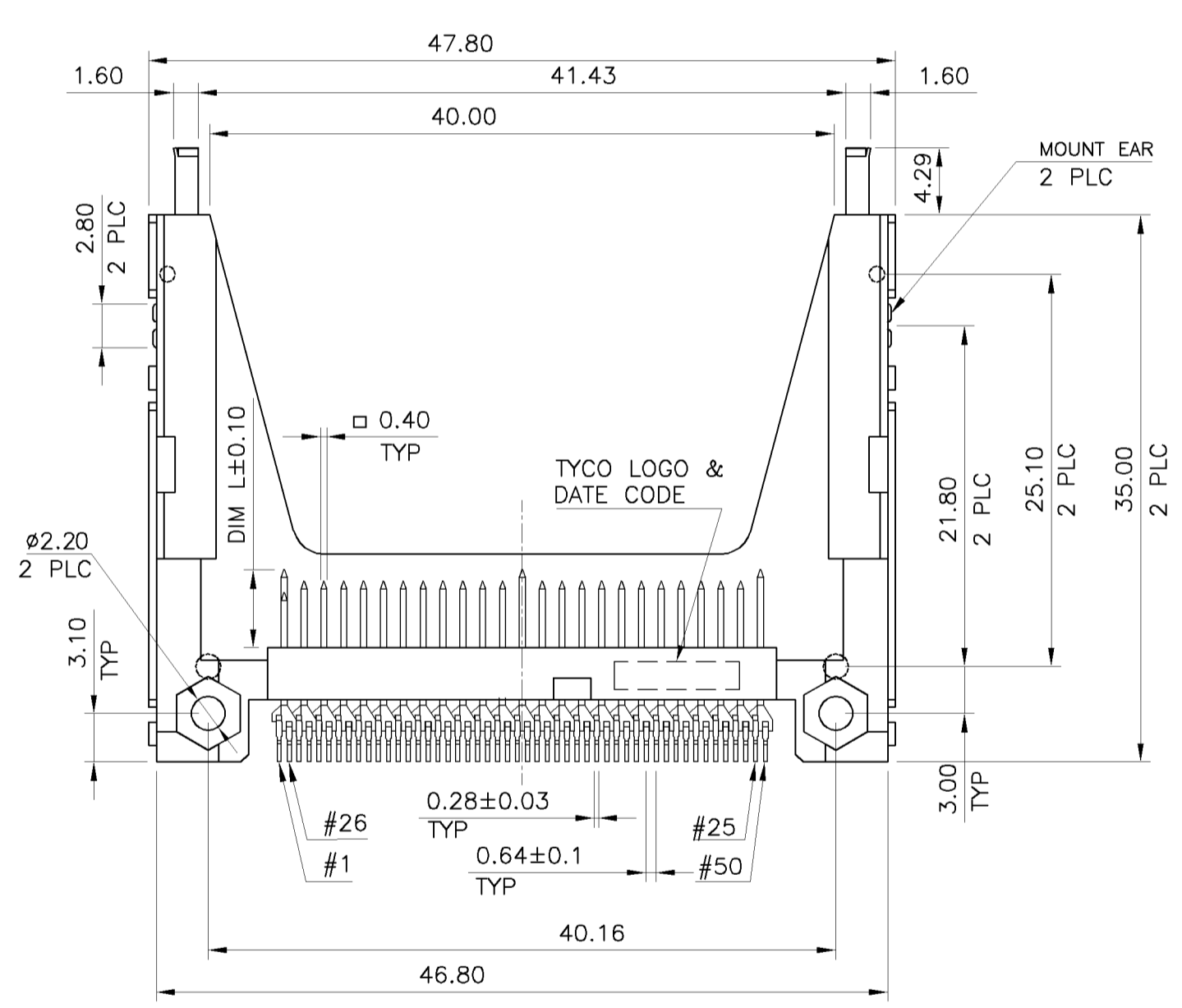

POWER	5.00mm
GENERAL	4.25mm
DETECT	3.50mm
PIN TYPE	INTERFACE DIM. L

1734449-1
 PART NUMBER

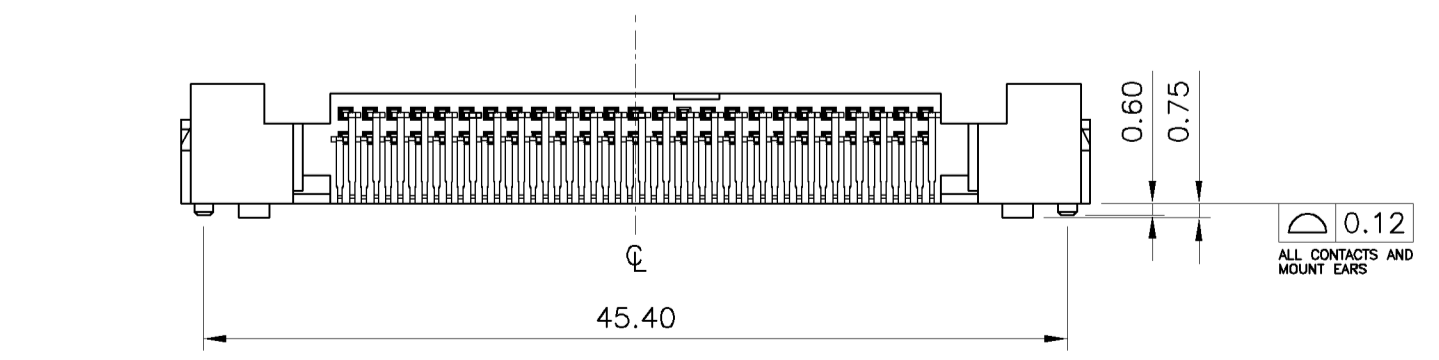

THIS DRAWING IS A CONTROLLED DOCUMENT.		DWN O. HU 03MAY2007	Tyco Electronics Corporation Taipei, Taiwan	
DIMENSIONS: MM		CHK S. HOU 03MAY2007		
TOLERANCES UNLESS OTHERWISE SPECIFIED:		APVD W.J. KE 03MAY2007	NAME	
0 PLC ± 0.5		PRODUCT SPEC		
1 PLC ± 0.3		108-57134		
2 PLC ± 0.2		QUALIFICATION TEST REPORT		
3 PLC ± -		501-57118		
4 PLC ± -		WEIGHT 4.145 GRAMS		
ANGLES ± -		A300779 C=1734449		
FINISH		RESTRICTED TO		
SEE NOTE		SEE NOTE		
MATERIAL		CUSTOMER DRAWING		
SEE NOTE		SCALE - SHEET 1 OF 2 REV A		

THIS DRAWING IS UNPUBLISHED. RELEASED FOR PUBLICATION
 © COPYRIGHT BY TYCO ELECTRONICS CORPORATION. ALL RIGHTS RESERVED.

LOC	DIST	REVISIONS					
DW	—	P	LTR	DESCRIPTION	DATE	DWN	APVD
				SEE SHEET 1.			

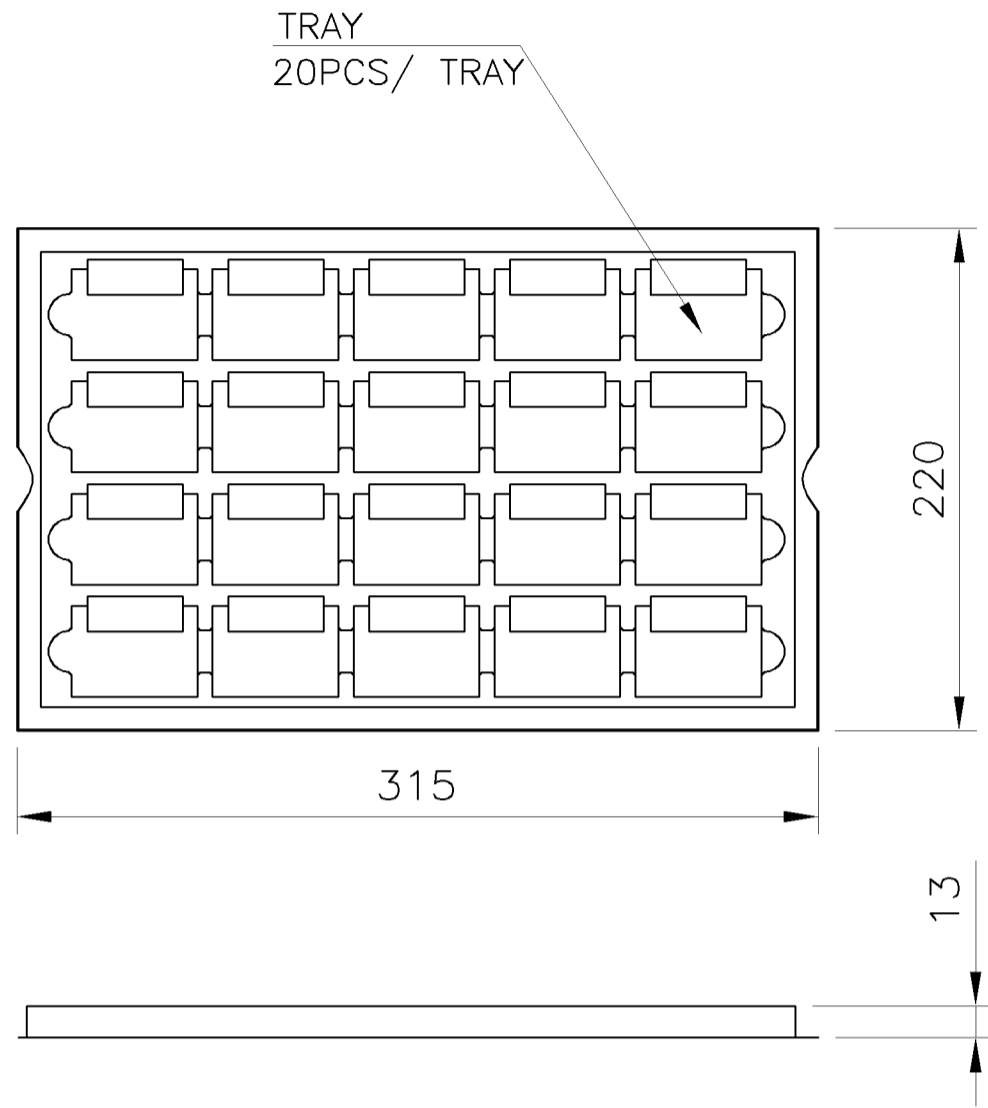

CARTON SIZE
457(L)X330(W)X292(H)

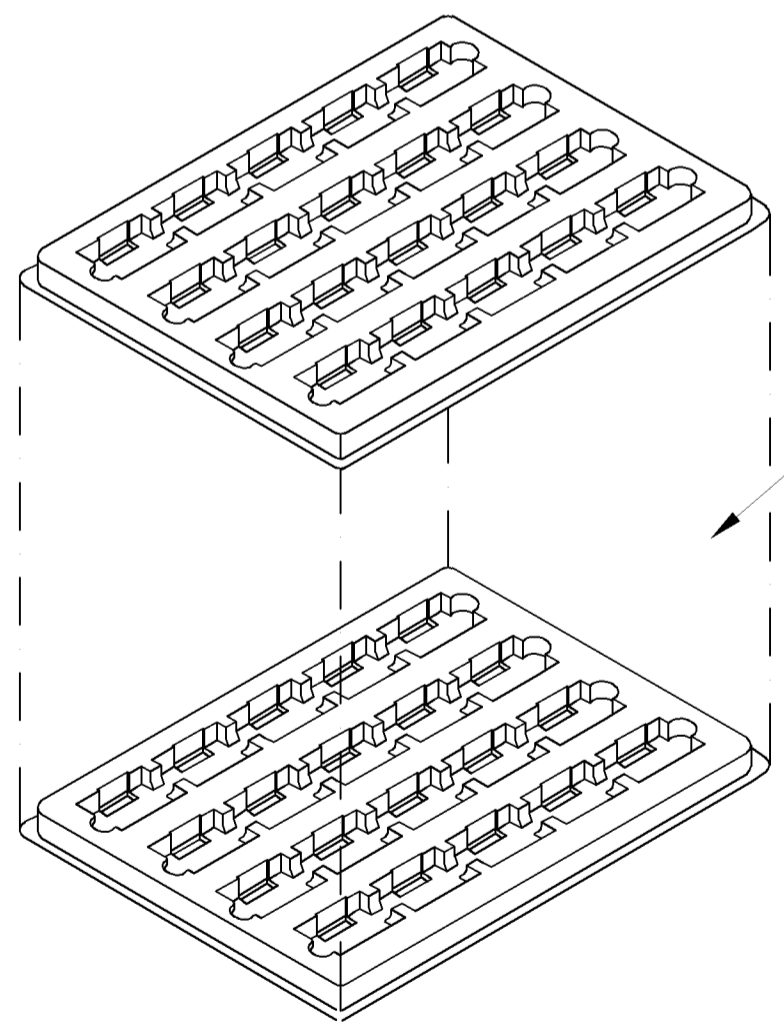
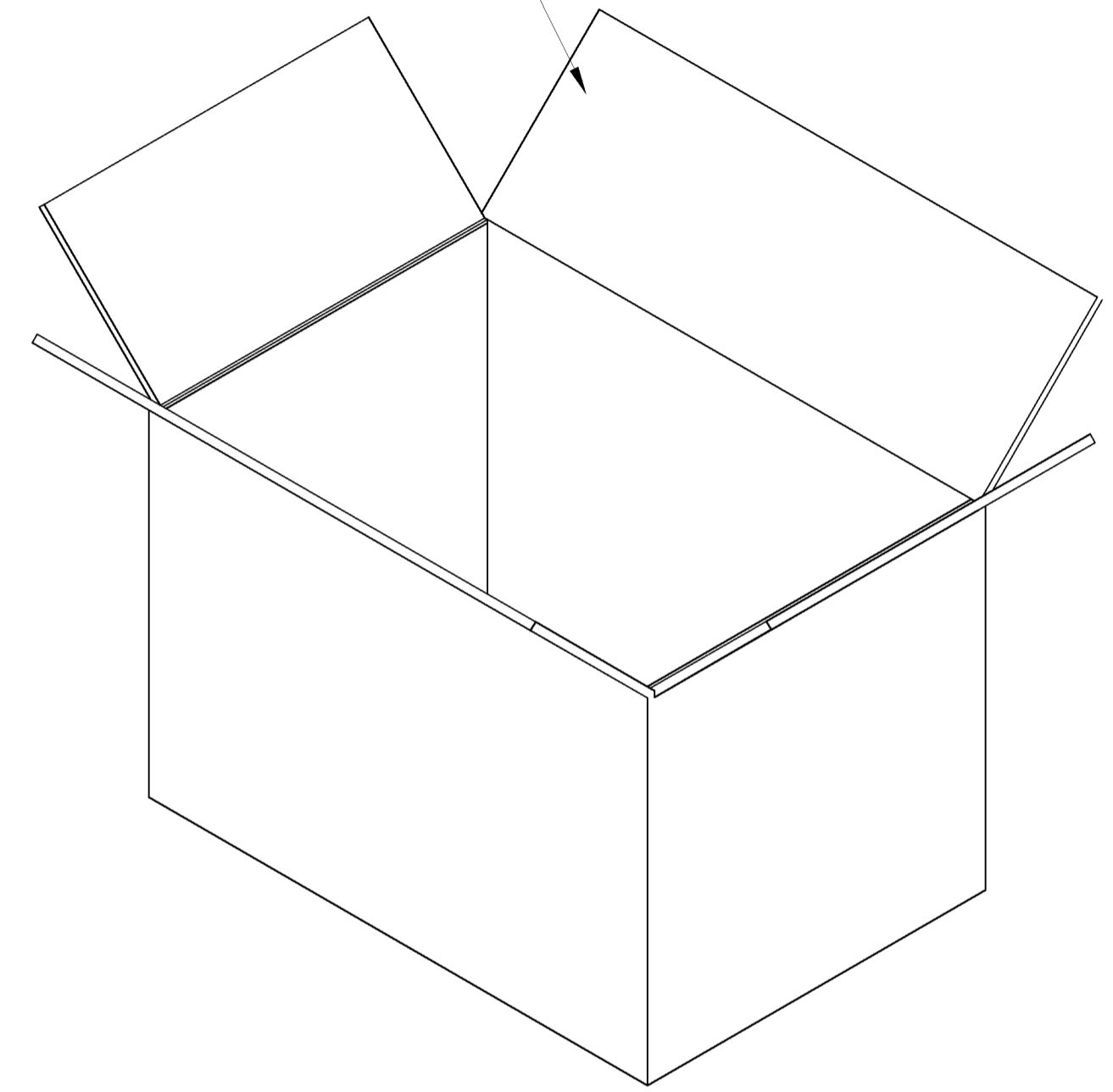

TOTAL: 32 TRAYS

NOTE:
1. TOP LAYER IS EMPTY.

8.4 Kg	7.6 Kg	1000
G.W	N.W	QUANTITY

THIS DRAWING IS A CONTROLLED DOCUMENT.		DWN O. HU	03MAY2007	tyco Tyco Electronics Corporation	
DIMENSIONS: MM		CHK S. HOU	03MAY2007	Electronics Taipei, Taiwan	
TOLERANCES UNLESS OTHERWISE SPECIFIED:		APVD W.J. KE	03MAY2007	NAME	
0 PLC ± -		PRODUCT SPEC		PIN HEADER TYPE 2, 50 POS, SMT, BOTTOM BOARD, COMPACT FLASH CARD	
1 PLC ± -		APPLICATION SPEC		SIZE	RESTRICTED TO
2 PLC ± -		WEIGHT		A3	—
3 PLC ± -		CUSTOMER DRAWING		CAGE CODE	
4 PLC ± -		SCALE		00779	
ANGLES ± -		SHEET		C=1734449	
FINISH		REV			A